

# **SOONHAN IO2K-SQP2 H/W Manual**

2004.7.1

Rev.1.1

**SOONHAN Engineering Corp.**

<b>1. External Shape .....</b>	<b>3</b>
<b>2. Connecting Power .....</b>	<b>3</b>
<b>3. Pin Assignment .....</b>	<b>4</b>
<b>4. Comparison with STC-136 .....</b>	<b>6</b>
<b>5. Wiring .....</b>	<b>7</b>
<b>5.1 Transceiver I/O .....</b>	<b>7</b>
<b>5.2 Connect to Digital Quadrature Encoder .....</b>	<b>8</b>
<b>5.3 Amp Enable Wiring .....</b>	<b>9</b>
<b>5.4 Amp Fault .....</b>	<b>11</b>
<b>5.5 Alarm Clear (Amp Reset) .....</b>	<b>12</b>
<b>5.6 Sensor .....</b>	<b>13</b>
<b>5.7 Node I/O .....</b>	<b>14</b>
<b>5.8 User Input .....</b>	<b>16</b>
<b>5.9 User Output .....</b>	<b>19</b>

## 1. External Shape

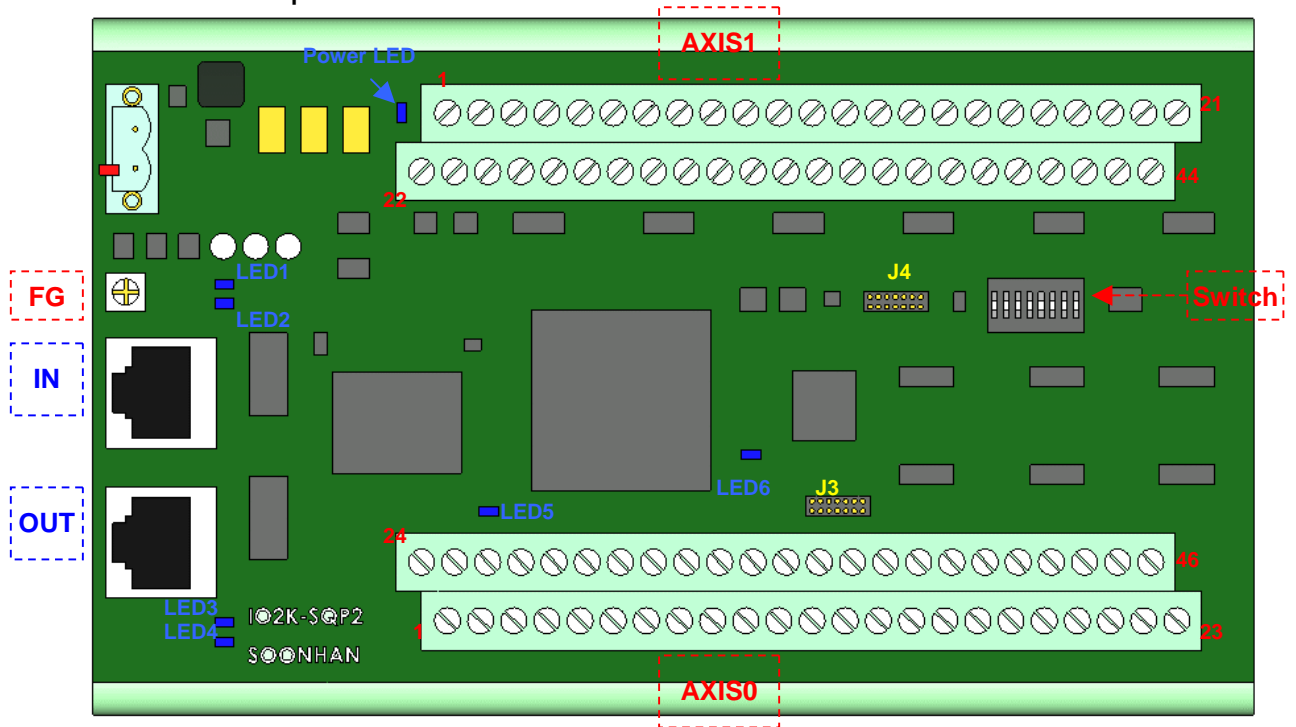

## 2. Connecting Power

< Power Connector >

Modular : Sauro CIM020V5

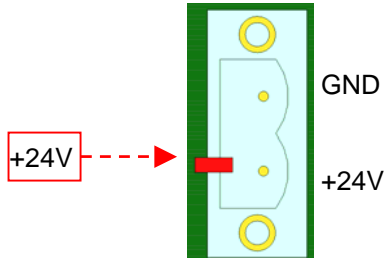

Mating : Sauro CVF020D5

< SynqNet >

Modular Jack : AMP 1116202-1 Category 5 High

< I/O >

Sauro PSB020D5

FG : Frame GND

Power LED : display power

LED 1 : SynqNet IN Link

LED 2 : SynqNet IN State

LED 3 : SynqNet OUT Link

LED 4 : SynqNet OUT Rptr

### 3. Pin Assignment

#### Connector for AXIS0

Pin	Signal	Signal	Pin	Description	P.
1	Enc0_A+	Enc0_A-	24	Encoder Phase A	8
2	Enc0_B+	Enc0_B-	25	Encoder Phase B	
3	Enc0_I+	Enc0_I-	26	Encoder Phase I	
4	Home0_IN	5V_OUT	27	Home Sensor	13
5	Pos_Lim0_IN	GND	28	Pos. Limit Sensor	
6	Neg_Lim0_IN	HomeLim0_Rtn	29	Neg. Limit Sensor & Sensor Rtn	
7	Amp_Flt0_IN	Amp_Flt0_Rtn	30	Amp Fault	11
8	Amp_En0_Collector	Amp_En0_Emitter	31	Amp Enable	9
9	Amp_Rst0_Collector	Amp_Rst0_Emitter	32	Amp Reset (Alarm Clear)	12
10	Brk_Appd0_Collector	Brk_Appd0_Emitter	33	Brake Append	
11	Tx0_0+	Tx0_0-	34	Transceiver A <i>(CW/CCW, Pulse/Dir)</i>	7
12	Tx0_1+	Tx0_1-	35	Transceiver B <i>(CW/CCW, Pulse/Dir)</i>	
13	GND	GP_Opto_IN0_0	36	Opto-Isolated In	16, 17
14	GP_Opto_IN0_1	GP_Opto_IN0_2	37	Opto-Isolated In	
15	GP_Opto_IN0_3	GP_Opto_IN0_4	38	Opto-Isolated In	
16	GP_Opto_IN0_5	GP_Opto_IN0_6	39	Opto-Isolated In	
17	GP_Opto_IN0_7	GP_Opto_IN0_8	40	Opto-Isolated In	
18	GP_Opto_IN0_Rtn0	GP_Opto_IN0_Rtn1	41	Opto-Isolated In Rtn	
19	24V_IN	GP_Opto_OUT0_0	42	Opto-Isolated Out	18
20	GP_Opto_OUT0_1	GP_Opto_OUT0_2	43	Opto-Isolated Out	
21	GP_Opto_OUT0_3	GP_Opto_OUT0_Rtn	44	Opto-Isolated Out Rtn	
22	Node_Alarm_Collector	Node_Alarm_Emitter	45	Node Alarm Out	14
23	Node_Disable_IN	Node_Disable_Rtn	46	Node Disable In <i>(E-Stop In)</i>	15

#### Connector for AXIS1

Pin	Signal	Signal	Pin	Description	P.
1	Enc1_A+	Enc1_A-	22	Encoder Phase A	8
2	Enc1_B+	Enc1_B-	23	Encoder Phase B	
3	Enc1_I+	Enc1_I-	24	Encoder Phase I	
4	Home1_IN	5V_OUT	25	Home Sensor	13
5	Pos_Lim1_IN	GND	26	Pos. Limit Sensor	
6	Neg_Lim1_IN	HomeLim1_Rtn	27	Neg. Limit Sensor & Sensor Rtn	

7	Amp_Flt1_IN	Amp_Flt1_Rtn	28	<i>Amp Fault</i>	11
8	Amp_En1_Collector	Amp_En1_Emitter	29	<i>Amp Enable</i>	9
9	Amp_Rst1_Collector	Amp_Rst1_Emitter	30	<i>Amp Reset (Alarm Clear)</i>	12
10	Brk_Appd1_Collector	Brk_Appd1_Emitter	31	<i>Brake Append</i>	
11	Tx1_0+	Tx1_0-	32	<i>Transceiver A (CW/CCW, Pulse/Dir)</i>	7
12	Tx1_1+	Tx1_1-	33	<i>Transceiver B (CW/CCW, Pulse/Dir)</i>	
13	GND	GP_Opto_IN1_0	34	<i>Opto-Isolated In</i>	16, 17
14	GP_Opto_IN1_1	GP_Opto_IN1_2	35	<i>Opto-Isolated In</i>	
15	GP_Opto_IN1_3	GP_Opto_IN1_4	36	<i>Opto-Isolated In</i>	
16	GP_Opto_IN1_5	GP_Opto_IN1_6	37	<i>Opto-Isolated In</i>	
17	GP_Opto_IN1_7	GP_Opto_IN1_8	38	<i>Opto-Isolated In</i>	
18	GP_Opto_IN1_Rtn0	GP_Opto_IN1_Rtn1	39	<i>Opto-Isolated In Rtn</i>	
19	24V_IN	GP_Opto_OUT1_0	40	<i>Opto-Isolated Out</i>	18
20	GP_Opto_OUT1_1	GP_Opto_OUT1_2	41	<i>Opto-Isolated Out</i>	
21	GP_Opto_OUT1_3	GP_Opto_OUT1_Rtn	42	<i>Opto-Isolated Out Rtn</i>	

#### 4. Comparison with STC-136

IO2K-SQP2's Interfacing with stepper and servo pack is almost same as STC-136.

Signal	STC-136		IO2K-SQP2	
	Pin Number		Pin Number	
	AXIS 0	AXIS 1	AXIS 0	AXIS 1
Enc_A+, Enc_A-	4, 38	18, 52	1, 24	1, 22
Enc_B+, Enc_B-	5, 39	19, 53	2, 25	2, 23
Enc_I+, Enc_I-	6, 40	20, 54	3, 26	3, 24
Home, Pos, Neg, Rtn	7, 8, 9, 43	21, 22, 23, 57	4, 5, 6, 29	4, 5, 6, 27
5V_OUT, Gnd	41, 42	55, 56	27, 28	25, 26
Amp_Flt_In, Rtn	12, 46	26, 60	7, 30	7, 28
Amp_En_Collector, Emitter	13, 47	27, 61	8, 31	8, 29
XcvrA+, XcvrA-	15, 49	29, 63	11, 34	11, 32
XcvrB+, XcvrB-	16, 50	30, 64	12, 35	12, 33
UserIO, Rtn	14, 48	32, 66	14 ~	14 ~

## 5. Wiring

### 5.1 Transceiver I/O

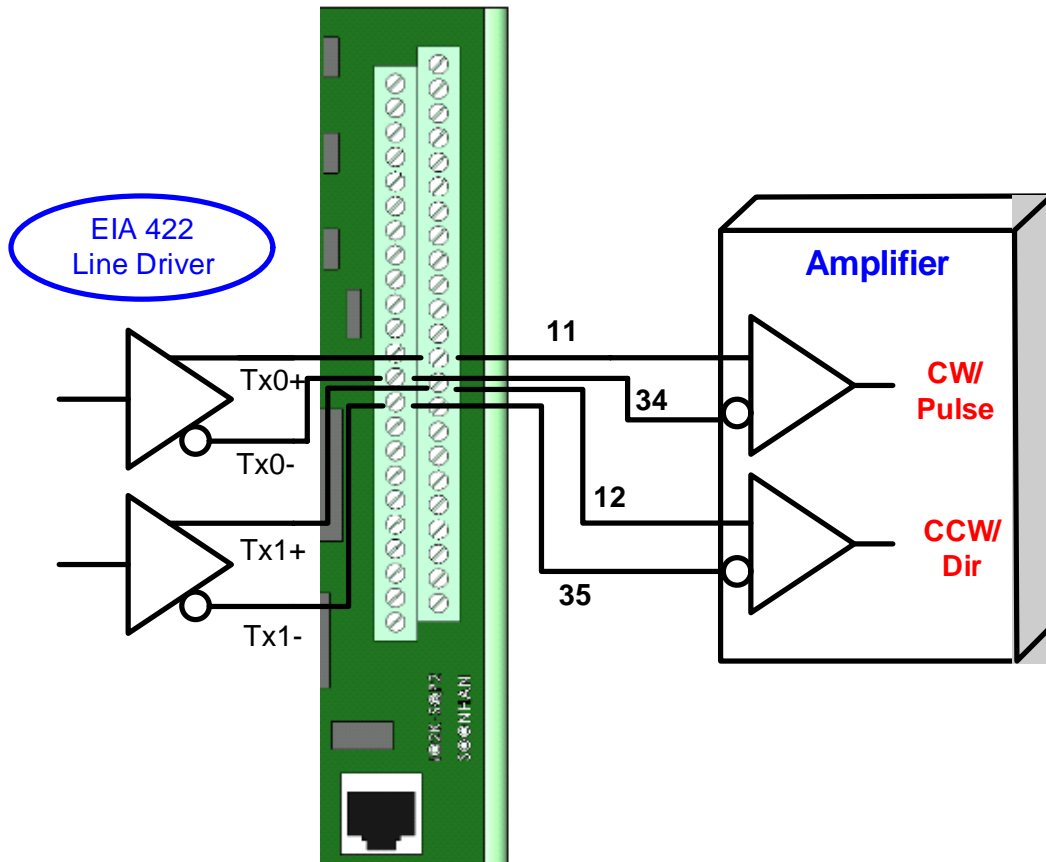

## 5.2 Connect to Digital Quadrature Encoder

- Connect to differential encoders (digital)

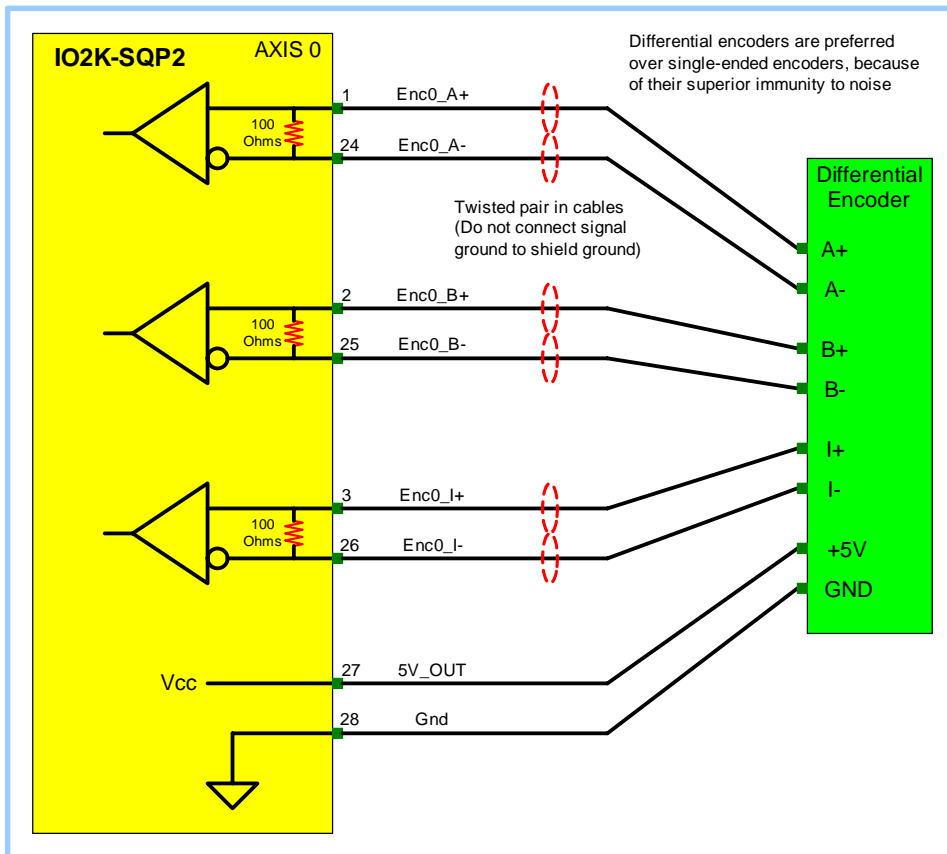

- Connect to single-ended encoders (digital)

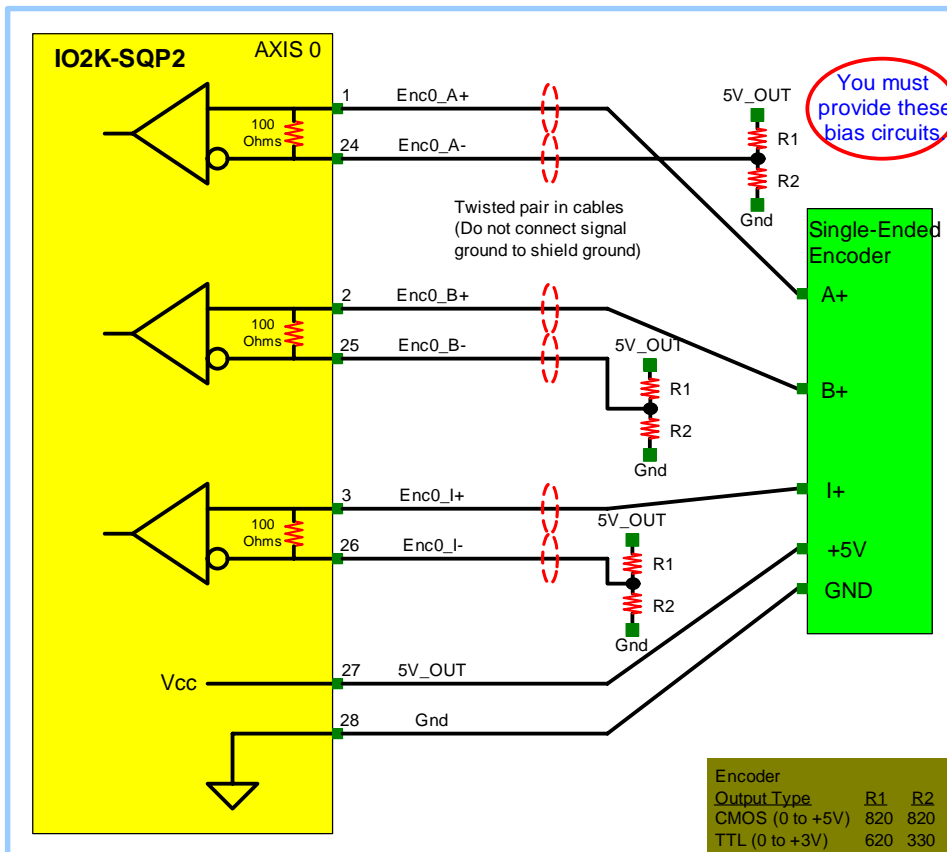



### 5.3 Amp Enable Wiring

< Active High >

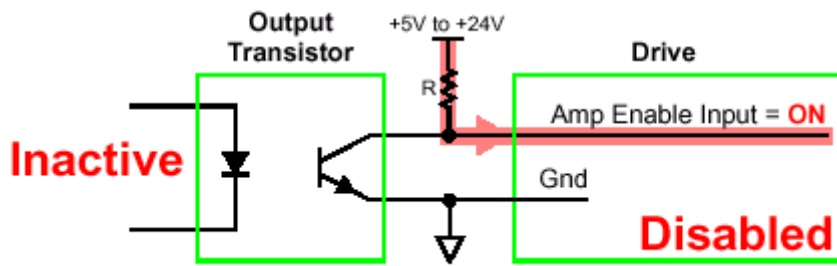
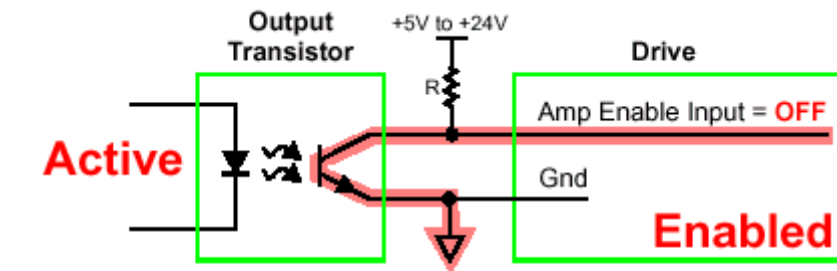

< Active Low >

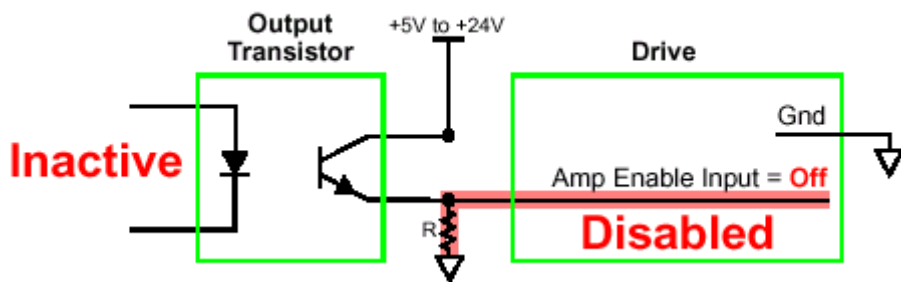
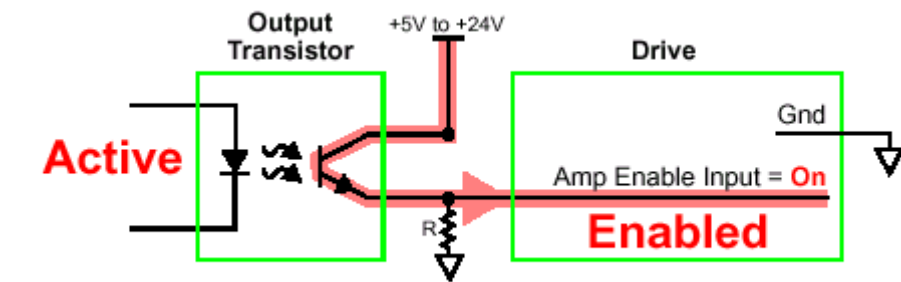

< Active Low Wiring (AXIS0) >

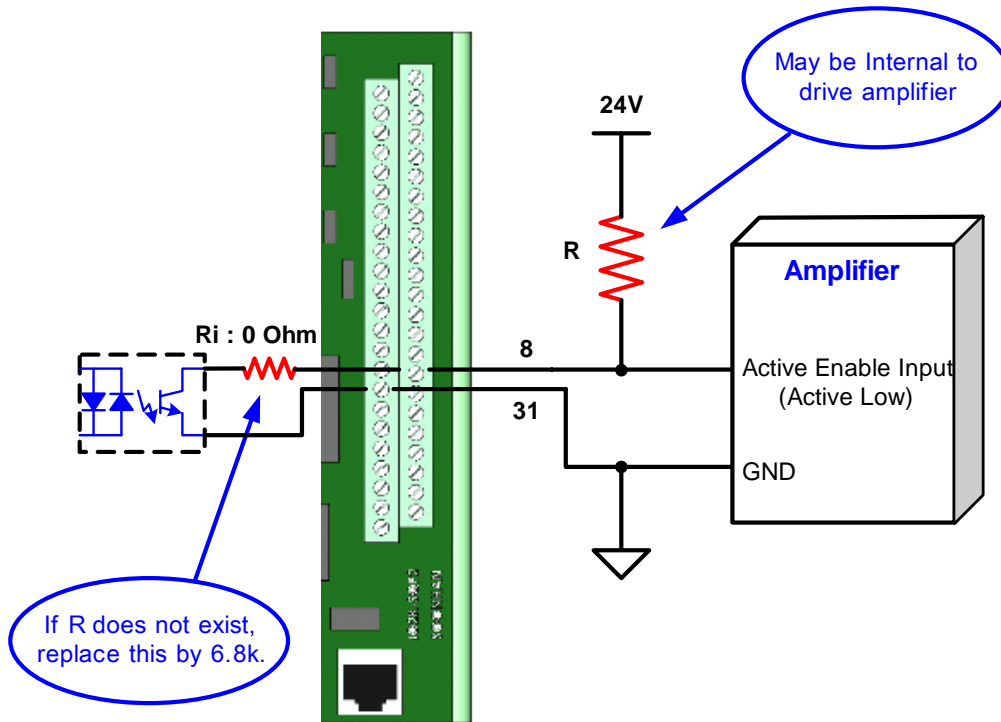

< Active High Wiring (AXIS0) >

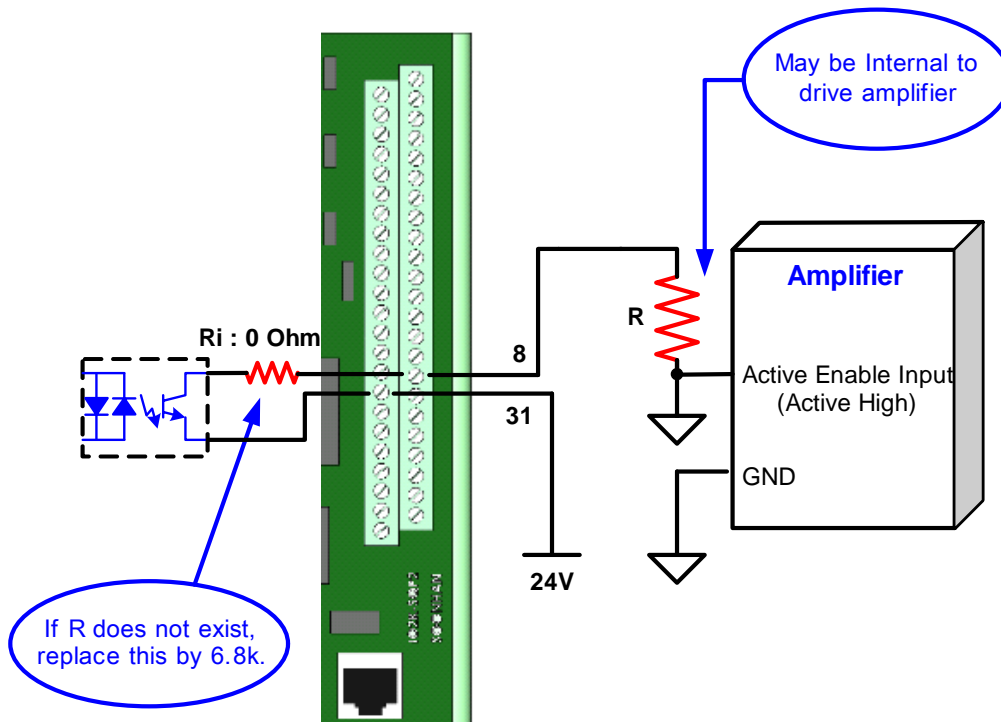

R<sub>i</sub>

AXIS	AXIS0	AXIS1	
Resistor Number	R107	R118	

### 5.4 Amp Fault

< Pull Up Logic >

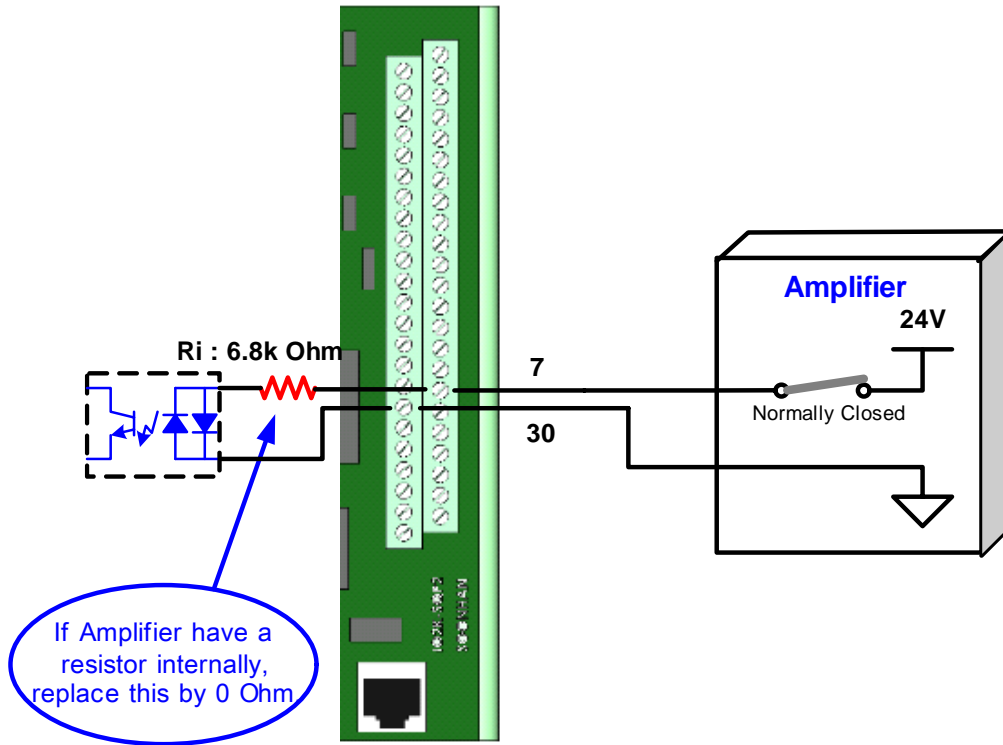

< Pull Down Logic >

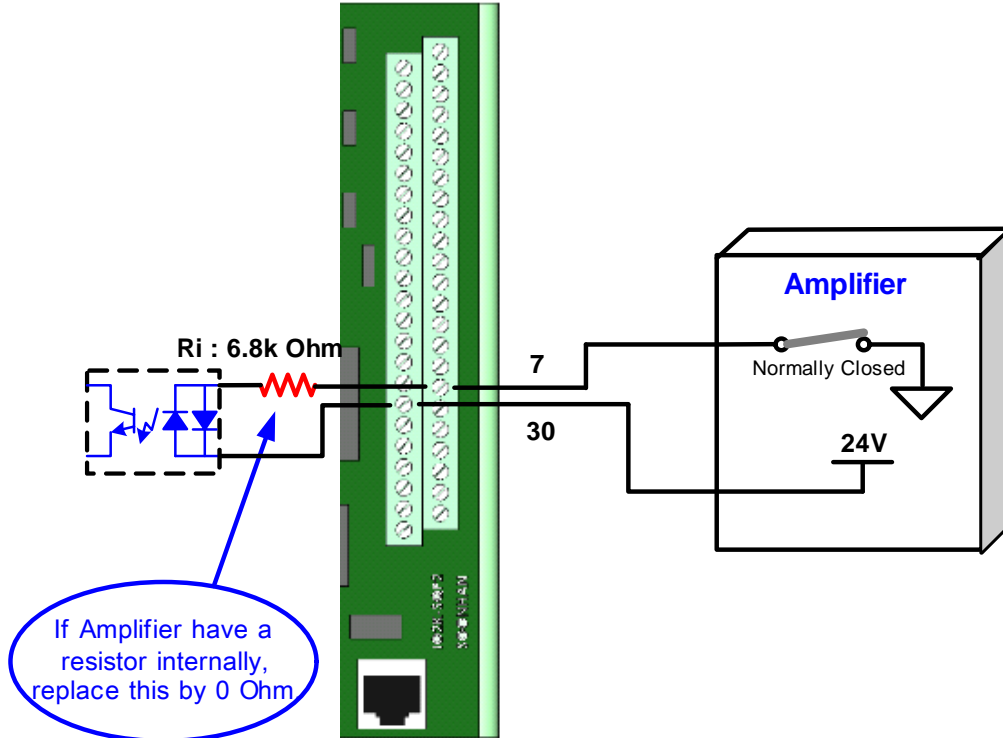

**Ri**

AXIS	AXIS0	AXIS1	
------	-------	-------	--

Resistor Number	R110	R121	
-----------------	------	------	--

**5.5 Alarm Clear (Amp Reset)**

< Active Low Wiring (AXIS0) >

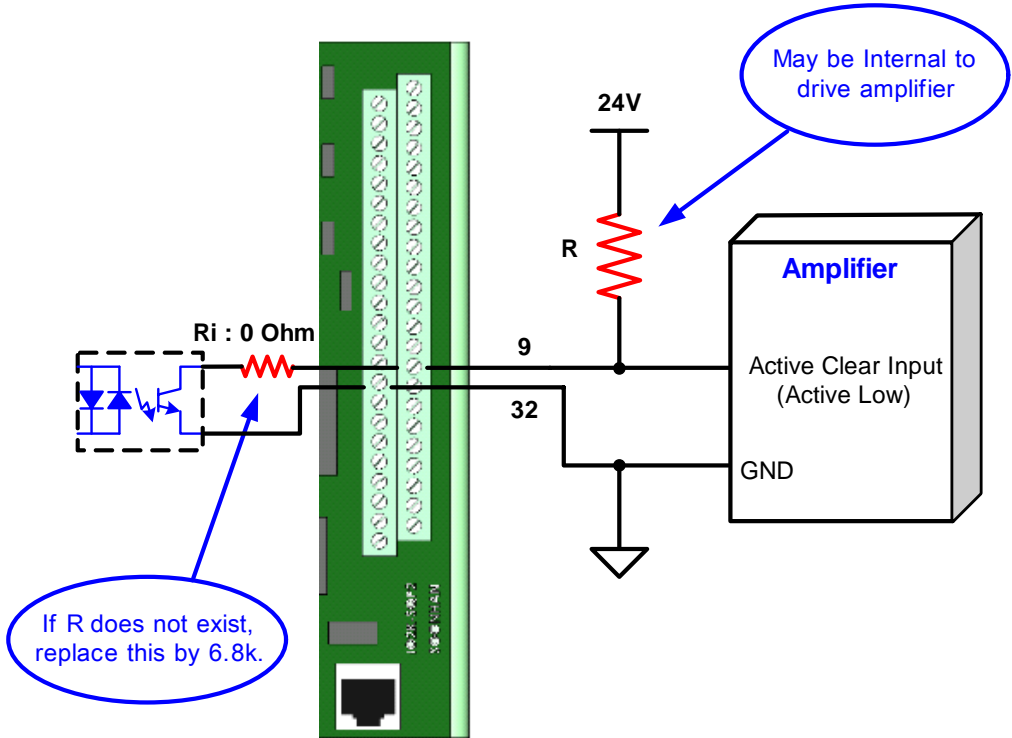

< Active High Wiring (AXIS0) >

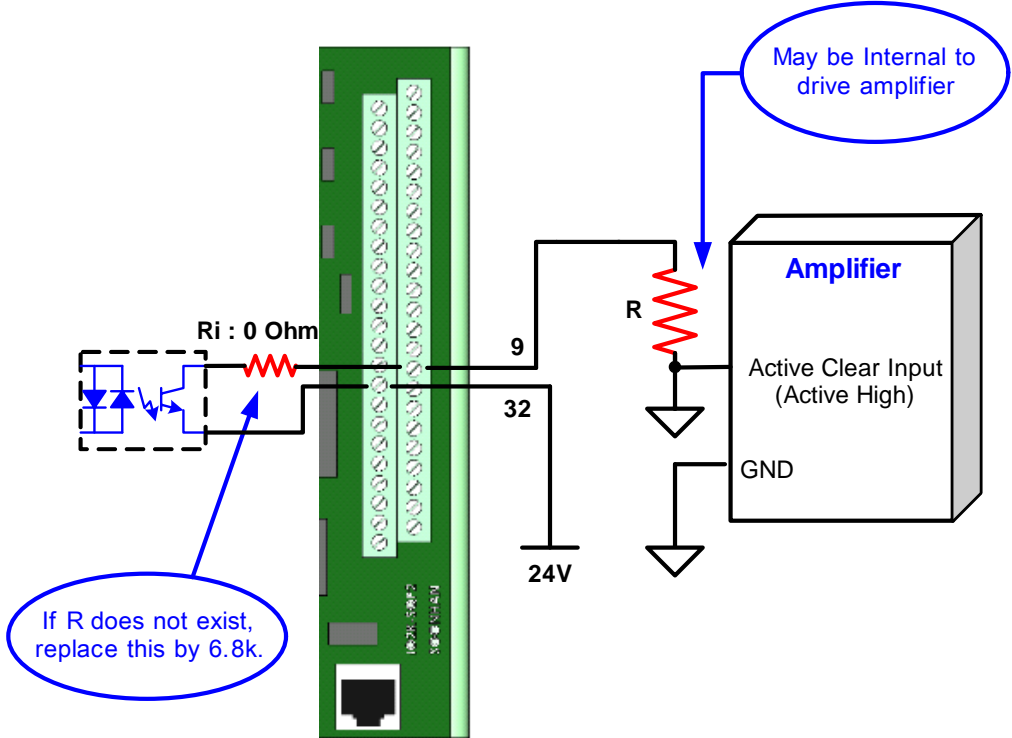

Ri

AXIS	AXIS0	AXIS1	
Resistor Number	R142	R167	

### 5.6 Sensor

< Common GND Logic >

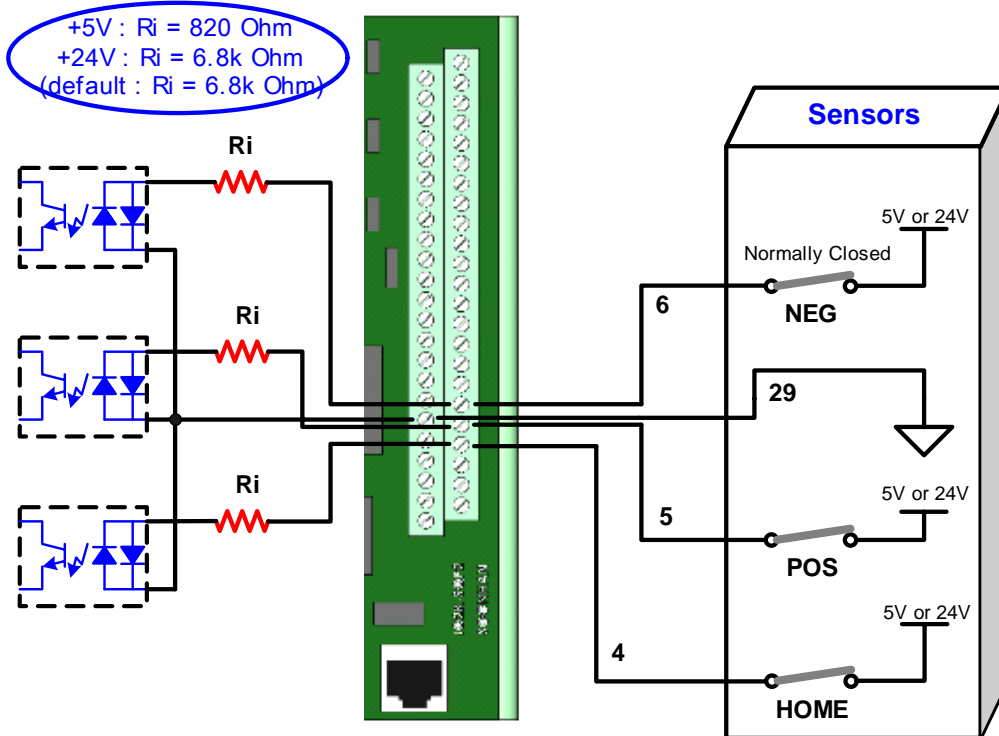

< Common VCC Logic >

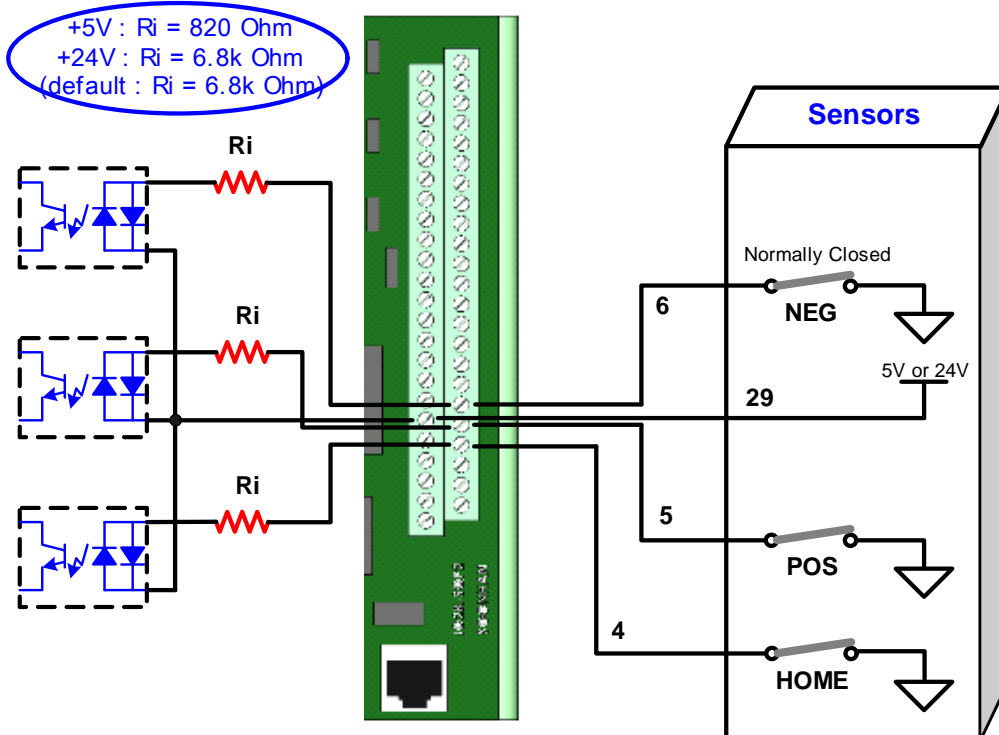

Ri

AXIS	AXIS0	AXIS1	
Resistor Number	R111, R112, R115	R122, R123, R124	Neg, Pos, Home

5.7 Node I/O

- Node Alarm

< Pull Up Logic >

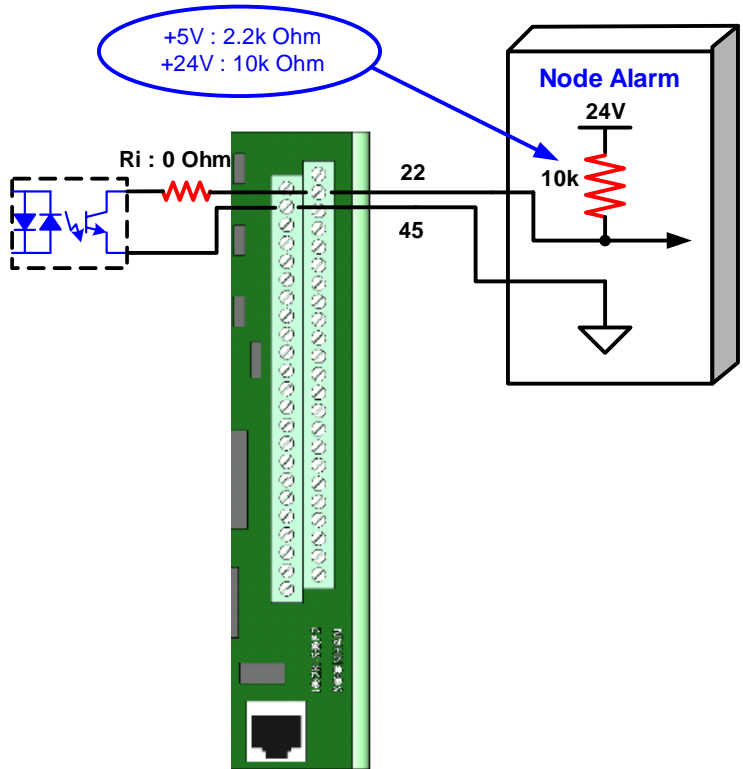

< Pull Down Logic >

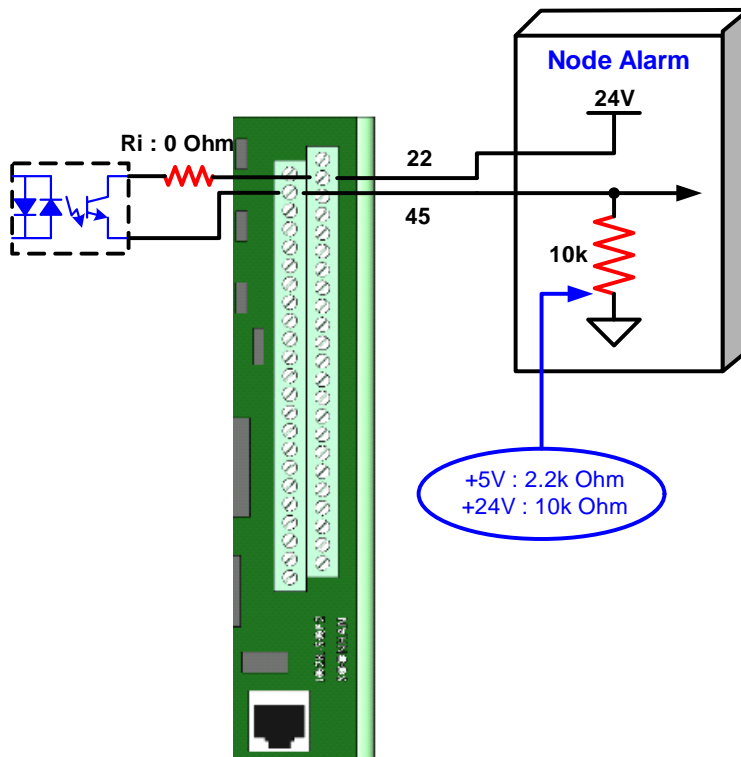

**Ri**

AXIS	AXIS0		
Resistor Number	R114		

- Node Disable (E-Stop In)

< Pull Up Logic >

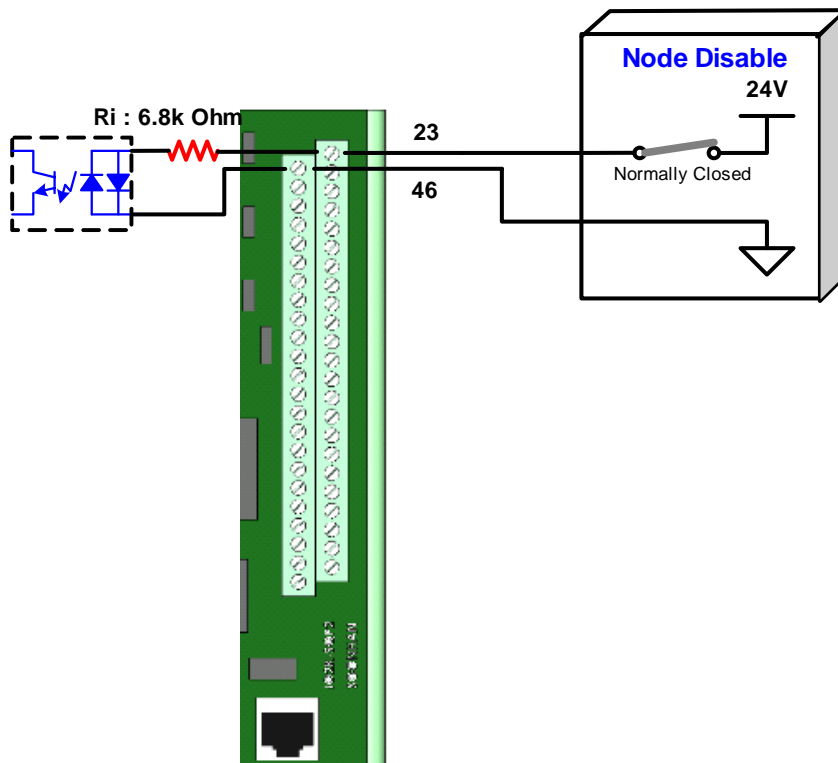

< Pull Down Logic >

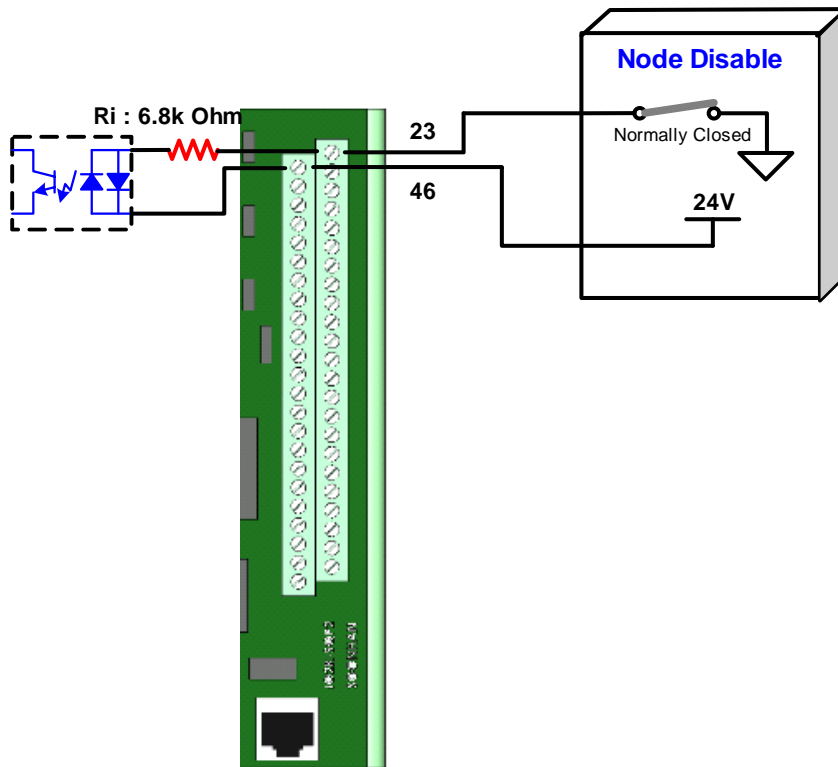

**Ri**

AXIS	AXIS0		
Resistor Number	R116		

**5.8 User Input**

< Common GND Logic >



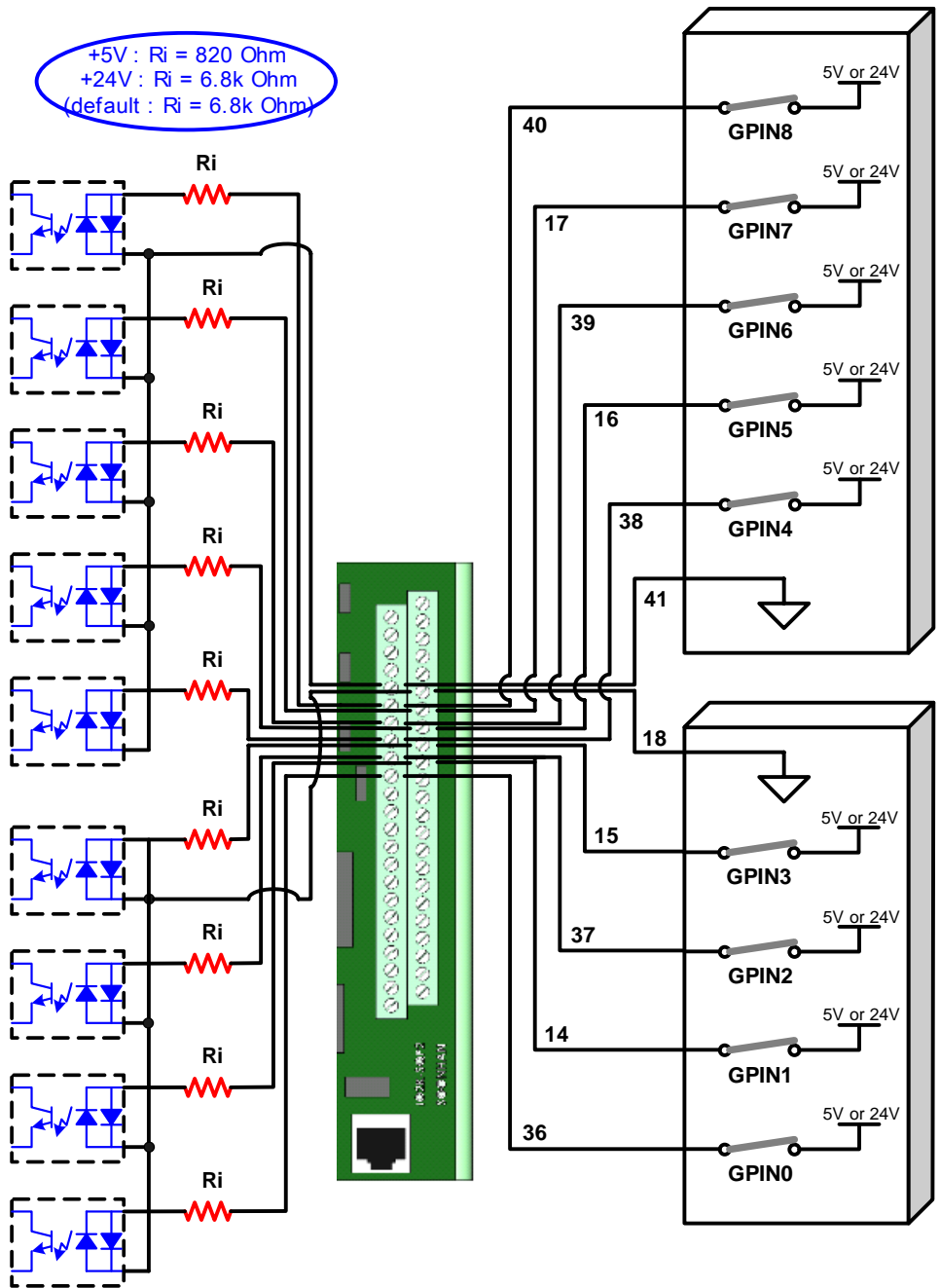

< Common VCC Logic >

+5V : Ri = 820 Ohm  
 +24V : Ri = 6.8k Ohm  
 (default : Ri = 6.8k Ohm)

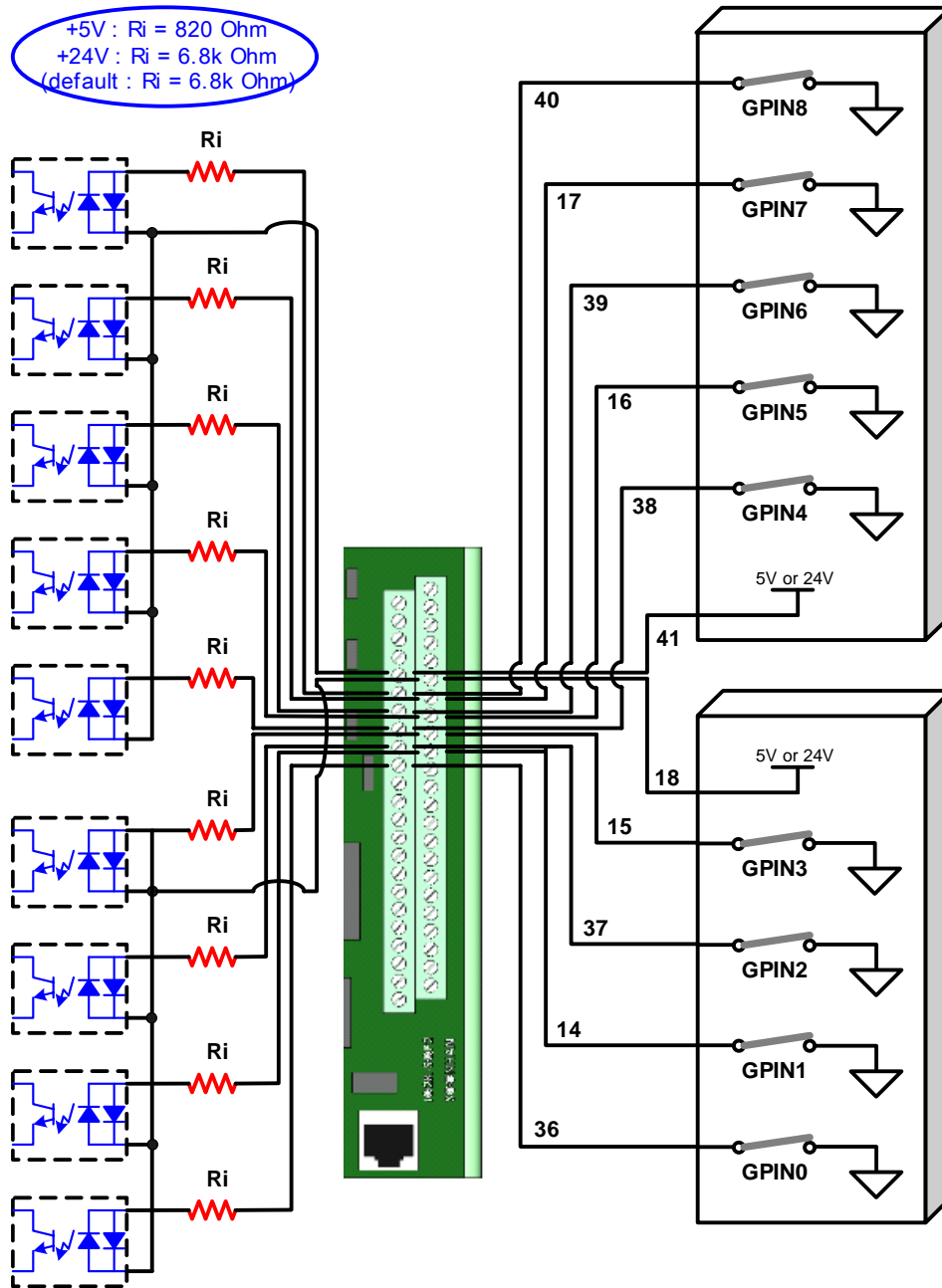

Ri

AXIS	AXIS0	AXIS1	
Resistor Number	R125	R150	GPIN0
	R129	R154	GPIN1
	R133	R158	GPIN2
	R139	R164	GPIN3
	R144	R169	GPIN4
	R146	R171	GPIN5
	R148	R173	GPIN6
	R149	R174	GPIN7
	R147	R172	GPIN8

### 5.9 User Output

< Common GND Logic >

